

SOCRADES: a framework for developing Intelligent systems in manufacturing

A. Cannata¹, M. Gerosa¹, M. Taisch¹

¹ Department of Management, Economics and Industrial Engineering, Politecnico di Milano, Milano, Italy
(alessandro.cannata@polimi.it, marco.gerosa@polimi.it, marco.taisch@polimi.it)

Abstract – Nowadays two main reasons are determining the increased number of intelligent systems in manufacturing. The first one is market-driven: demand is more and more variable and mass customization is the new way to compete in manufacturing, requiring feasible reconfigurable manufacturing systems. The second one is technology-pushed: the increasing availability of high-performance, low-power electronic components and the emerging wireless technologies are boosting the creation of intelligent systems (with personal intelligent perception, reasoning, etc.). However research should still be done in intelligent systems' field. Since the complexity both of the topic and of the consequences on manufacturing domain, a framework for addressing the overall field should be defined. We propose the framework adopted in SOCRADES, a European research project exploiting Service Oriented Architecture paradigm both at the device and at the application level. Finally the impacts of SOCRADES architecture on manufacturing performance are described and motivated.

Keywords - SOA, Embedded devices, wireless, intelligent system, enterprise integration, system engineering & management

I. CONTEXT DEFINITION

Nowadays market's demand is going towards mass customization where large numbers of product variants are required by customers. This trend involves production strategy changes in order to achieve a Manufacture-to-Order paradigm and the adoption of highly flexible systems to properly react to mix variability. Moreover, highly fluctuating demand and new products introduction require new manufacturing systems that are able to handle high variability with limited cost expenditure. This kind of new manufacturing systems must evolve to meet rapidly changing requirements in efficient and effective fashion. Today, re-designing and re-programming of automation and control systems, in order to change features of manufacturing systems, are still too expensive and too slow.

On the other hand, there is an increasing availability of affordable, high-performance, low-power electronic components and the Internet / Ethernet (wired or wireless) technologies. These technologies, as the basic carriers for interconnecting electronic devices, are at the basis for communication improvement and heterogeneous devices integration, with particular emphasis on platform independence, real-time requirements, robustness and

security. Moreover, these technologies can be leveraged to build advanced functionality into embedded devices, thus enabling new distributed application paradigms based on interconnected "smart devices" with a high level of autonomy.

In this context, intelligent systems will support the enhancement of manufacturing systems. Manufacturing systems composed of autonomous entities, each one provided with personal intelligent perception, reasoning, learning, acting reason, and seamless interaction with other system units, will enable more effective and straight management and reconfiguration.

Even if intelligent systems are expected to have positive impact on manufacturing performance, especially in terms of systems design and management, still research effort should be carried out in this field in order to provide a reliable and effective framework for the implementation.

A research stream for reaching intelligent systems is based on Service-Oriented Architectures (SOA). SOA offer the potential to provide the necessary system visibility and device interoperability in complex automation systems subject to frequent changes. SOA is basically an architectural paradigm that defines mechanisms to publish, find and compose services adopting loose coupling logic and open standards. Hence SOA paradigm is particularly applicable for environments where reconfigurability is required. This approach expands the use of the service-oriented architecture (SOA) paradigm, implemented through Web Services technologies, at the ad hoc device network level enabling the adoption of a unifying technology for all levels of the enterprise, from low-level real-time embedded sensors and actuators devices to enterprise business processes. This new approach poses many challenges and opportunities for new services and applications, but also raises new questions.

SOCRADES (Service-Oriented Cross-layer Infrastructure for Distributed smart Embedded devices) [1] is a European research project addressing SOA-based manufacturing paradigm. Its primary objective is to develop a design, execution and management platform for next-generation industrial automation systems, exploiting Service Oriented Architecture paradigm both at the device and at the application level. SOCRADES will create new methodologies, technologies and tools for the modeling, design, implementation and operation of networked systems made up of smart embedded devices. Both wired

and wireless networking technologies will be considered for the network implementation analysis.

II. SOCRADES FRAMEWORK FOR INTELLIGENT SYSTEMS

In order to address a complex issue such as intelligent systems development, an overall framework should be adopted. Fig. 1 presents the general architecture used in the SOCRADES project to face this matter.

SOCRADES fundamental paradigm is the Service-Oriented Architecture common infrastructure for seamless integration from enterprise level to device level applications. This is represented in Fig. 1 by the structure interconnecting all the Web Services (WS) that compose the general architecture. More than developing and specifying models, protocols and general architecture for web services, SOCRADES focus its efforts on the device level addressing problems concerning Wireless Sensor/Actuators Networks (WSAN) in order to develop reliable and efficient communication carriers (bottom right in Fig. 1). Moreover, even Enterprise Integration represents an important field of study in order to obtain and exploit benefits coming out from the use of SOA as middleware. Enterprise Integration is focused on the Enterprise systems WS of Fig.1. Finally the last relevant topic addressed by SOCRADES that completes the overall framework is System engineering & management (related to the Engineering system of Fig.1); this is relevant for exploiting all the opportunities in terms of dynamic reconfigurability and re-configuration come out from SOA adoption. Hereafter the four main areas of SOCRADES are described, stating the focus of each one.

A. Service-oriented Architecture

The key goal is to specify Service-oriented framework for device-level infrastructures, where system intelligence is implemented by intelligent physical agents embedded in smart devices. The umbrella paradigm underpinning novel system design is to consider the set of intelligent system units as a conglomerate of distributed, autonomous, intelligent, pro-active, fault-tolerant and

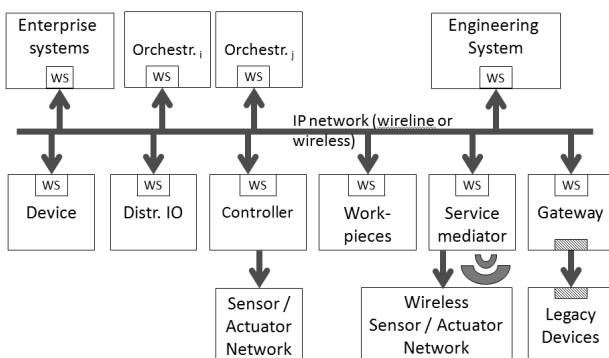

Fig. 1. The general architecture of the SOCRADES framework.

reusable units, which operate as a set of cooperating entities. These entities are capable of working in a proactive manner, initiating collaborative actions and dynamically interacting with each other in order to achieve both local and global objectives, down from the physical device control level up to the higher levels of the business process management system. These entities are represented in Fig. 1 by the Web Services interconnected to the SOA infrastructure (e.g. devices, orchestrators, controllers, work pieces, gateways, mediators, etc.)

In this area Devices Profile for Web Services (DPWS) [2] specification is being developed and improved. This specification identifies a minimal set of Web Services protocols useful in realizing networked architectures of Web Services-enabled devices. It is built on top of the SOAP, and relies on additional Web Services specifications, such as WS-Addressing and WS-Policy. The DPWS specification defines also a set of built-in services, such as WS-Discovery, WS-MetadataExchange, WS-Eventing. The DPWS stack provides a development toolkit for the user developing their own services. Moreover for this area the following aspects are being developed: Service orchestration, service management, service-enabled agent, semantic web services, and service gateway.

B. Wireless sensor/actuator network

This area focuses on sensor/actuator network that is a network of equal participants without any central control, in which sensors and actuators directly interact with each other with the objective of commonly solve day-to-day automation tasks. The objective is to specify new wireless communication protocols that provide the required reliability, safety, security and real-time parameters for embedded devices. Although, in theory, these protocols are not imperative for sensor/actuator networks, wired sensor/actuator networks would be of no practical relevance as the wiring of a high amount of sensor and actuator nodes would be difficult and not economic. In confirmation of this evidence, the domain of industrial communication shows the trend of adopting wireless technologies for networked embedded automation devices. Research on power supply for the network infrastructure as well as the sensor itself, development of new services with WSANs, merging of the DPWS application models with the latest architectures used in wireless technologies are being carried on.

C. Enterprise integration

This research stream is fundamental since one of the main relevant SOCRADES objectives is to enable the integration of device-level services with enterprise systems. The application of the SOA paradigm and Web Services technology, as proposed in SOCRADES, results in a single unifying application-level communications technology across the enterprise [3,4]. Hence a main relevant topic is the integration of aggregated device-level

services with higher level Web Services and business processes situated at the level of business applications - in particular Enterprise Resource Planning (ERP) systems - in order to demonstrate seamless integration of device level functionality into higher-order business application scenarios in manufacturing, logistics, or similar areas. The integration should not require changes to business application code, but be based on and leverage the Web Service-enablement of device networks as addressed by SOCRADES. The definition of new integration concepts taking into account the emerging requirements of business applications and the explosion of available information from the device level is considered in this SOCRADES's research stream; as well as the trend towards availability of real-time event information, which will be used to specify new enterprise integration approaches for applications such as business activity monitoring, overall equipment effectiveness optimization, maintenance optimization, etc.

D. System Engineering & Management

In order to handle the highly level of reconfigurability and complexity due to the use of SOA on a low-level application, tools and methods for systems engineering & management are needed [5]. Within this research stream, the main goal of SOCRADES is to specify systematic approaches and engineering tools that will facilitate the engineering of the overall system behavior. The goal is to combine support for the configuration and optimization of networked control capabilities with device management, configuration and lifecycle support services. End-users are needed to assist in exploring these new directions.

III. INTELLIGENT SYSTEMS ENABLE COLLABORATIVE AUTOMATION

SOCRADES adopts the "collaborative automation" [6] paradigm: the aim is to effectively develop tools and methods, to achieve flexible, reconfigurable, scalable, interoperable network-enabled collaboration between decentralized and distributed embedded systems.

The SOCRADES technical approach is to create a service-oriented ecosystem: networked systems are composed by smart embedded devices interacting with both physical and organizational environment, pursuing well-defined system goals. Taking the granularity of intelligence to the device level allows intelligent system behavior to be obtained by composing configurations of devices that introduce incremental fractions of the required intelligence. This approach favors adaptability and rapid reconfigurability, as re-programming of large monolithic systems is replaced by reconfiguring loosely coupled embedded units. From a functional perspective, the focus is on managing the vastly increased number of intelligent devices and mastering the associated complexity.

From a run-time infrastructure point of view, the focus will be on a new breed of very flexible real-time embedded devices (wired/wireless) that are fault-tolerant, reconfigurable, safe and secure. Auto-configuration management is a new challenge that will be addressed through basic plug-and-play and plug-and-run mechanisms. The use of device-level Service Oriented Architecture, will contribute to the creation of an open, flexible and agile environment, by extending the scope of the collaborative architecture approach through the application of a unique communications infrastructure, down from the lowest levels of the device hierarchy up into the manufacturing enterprise's higher-level business process management systems.

IV. IMPACTS ON MANUFACTURING

In this section we want to stress the most relevant impacts that SOCRADES (by developing the framework described above for intelligent systems) will generate on manufacturing performance.

1) *Reconfigurability*: the adoption of SOA and an ad-hoc services platform facilitates the discovery and composition of applications by re-configuration rather than reprogramming. There is no need for software re-programming of large monolithic systems but rather a reconfiguration of loosely coupled embedded units. Moreover through the adoption of tools able to support application design, simulation and monitoring of real-time intelligent embedded components it will be possible to manage the complex and changeable context in which reconfigurability will be required.

2) *Interoperability*: service-oriented architecture (SOA) paradigm, using opaque interface and loose coupling concept on widely heterogeneous devices, facilitates both the discovery and the composition of complex services that can use devices deployed in various platforms and networking technologies. Moreover, the elimination of cable connectors due to the adoption of wireless communication strongly facilitates an improved seamless interoperation. The utilization of widely heterogeneous systems is definitely allowed by adopting a common wireless architecture.

3) *Scalability*: this important requirement, especially in manufacturing, can be spontaneously supported by SOA and by an ad-hoc services platform. The identification of a new device can be done opaquely through SOA, without needing to deeply modify the overall system. This is much important for IT governance and for possible impacts on SMEs market, where IT investments are sometimes avoided due to scalability issues.

4) *Maintenance Optimisation-Diagnosability*: the technology behind SOA and the enhancement that SOCRADES is generating will support both the discovery/recognition of failures (sensors, resources, controllers, etc.) and their repair in a real-time and seamless fashion. The provision of a set of agile and

economic sensors/actuators will increase the granularity of the information that can be available for the overall (maintenance) system. This low level information will support high level business application thanks to seamless integration. With low level information available “on demand”, maintenance optimization will be strongly supported, e.g. by integrating device-level services and diagnostics with business applications in maintenance and asset management, actual device diagnostics data compared to stored device profiles for detecting alerting conditions, etc.

5) *Reusability*: SOA and WSN improve reusability of resources/devices that are encapsulated in services. Since every component can be easily recognized and managed by any SOA-enabled system and by the common wireless architecture, reusability increases. Even the reutilization of components into different systems will become feasible and seamless. This generates both cost reduction and sustainability enhancement.

6) *Intellectual Protection*: with SOCRADES SOA-enabled architecture a more effective Intellectual Protection will be possible, since the architecture itself is based on exposing services not the technology behind them. SOA will automatically hide how the service is furnished, showing only the functionality of the service itself. This feature can have a dramatic impact on collaboration among enterprises since exposure of own technology should become less risky.

7) *Cost efficiency*: SOCRADES, thanks to the developments in wireless communication, will allow cost reduction related to cables installation and maintenance. This includes material costs (e.g.: buying cost and maintenance cost), time-related costs (e.g.: time spent during installation, movement or elimination of resources), labor costs (e.g.: personnel cost for installing and maintaining). Moreover, thanks to the developed methods for system engineering an efficient and standardized tool that supports the overall system engineering and management will reduce general costs due to the time saved in designing phase and to the improved control on efficiency that will be feasible.

8) *New Applications*: thanks to the development of WSN, new business applications can become feasible. The elimination of cabling coupled with a reliable and secure communication will allow new functions, such as monitoring or controlling within harsh working environments.

9) *Business Activity Monitoring*: the increased granularity that can be seen from the enterprise system through the implementation of an effective seamless integration allow low level information being available for real-time measure of key performance indicators and for real-time reaction to relevant events and exceptions with minimized latency. This extremely important in today’s market performance control and improvement are required for competing in the manufacturing market.

10) *Mobile Equipment Assistance*: SOCRADES, by adopting the seamless integration strategy through SOA implementation, will easily allow the process of using

mobile devices as a mean to realize part of a business process or even as the end-devices to be monitored. The aim is to loosely couple the back-end systems (enterprise infrastructure) with the front-end ones (machines and devices available to the workforce on-site), but still be able to realize the whole business process in a flexible and dynamic way. A series of services can be realized such as remote diagnostics, predictive maintenance, etc.

11) *Overall Equipment Effectiveness*: the seamless integration of the manufacturing devices level into the business applications level is a basis for capturing information about equipment usage. With the adoption of this information a better utilization of assets (people, equipment, and materials) through a comprehensive view of overall equipment efficiency can be allowed. Relevance of this feature enabled by SOCRADES is based on possibility to have at high-level business application indicators based on low-level high-granular information.

12) *Customized manufacturing with late order freeze*: SOCRADES, by connecting the shop floor to the business system, will change the freeze period, which is the period during which the customer cannot change a product parameter. The start point of the freeze period can be stretched to the point, where the parameter is actually incorporated in the product (order penetration point). This kind of near real-time enterprise is obtained without efforts in integrating the different systems involved (MES, B2C application, etc.). Additionally, the customer can be informed about the production stage and the expected completion of the order in near real-time.

13) *Complexity management*: the explosion in number of embedded devices will require new tools and methods for managing a new degree of complexity. SOCRADES considers the management of this complexity. Since in the future complexity is expected to become a pervasive feature of manufacturing production requirements, being able to manage complexity will constitute a competitive advantage.

14) *Reactivity*: system engineering and management addressed by SOCRADES will contribute to enhance the reactivity of the overall enterprise, by supporting it with a more rapid and efficient tool for designing and validating systems. Moreover, thanks to the support of SOA and seamless Enterprise, integration reactivity will be boosted. This characteristic is extremely important for competing in future manufacturing market where demand will become more unpredictable and where rapid decision will become necessary to survive the competition.

15) *Integration*: SOCRADES, with the developments on SOA, WSN, Enterprise integration and system engineering and management will allow not only the integration within the enterprise but also between partners. Even if SOA is the enabling technology for integration all the research streams are necessary to obtain this possibility. Cross-border integration is fundamental to obtain collaborative manufacturing in order to create competitive collaborations in highly competing environments (where increasing required specialization

and systems complexity cannot be both solved by single enterprises by themselves).

V. CONCLUSIONS AND FUTURE DEVELOPMENT

The utilization of intelligent systems in manufacturing domain is expected to increase in the future. Nevertheless intelligent systems still need for research and development efforts in order to solve some issues that constrain actual implementation within the industries.

We presented the structure of SOCRADES, a European research project addressing SOA-based manufacturing paradigm. This project has been structured in order to address the main problem that intelligent systems composed of embedded devices are facing: in terms of architecture (SOA), communication (WSAN), integration (Enterprise integration) and modeling (System engineering & management).

In view of their expanding business and marketing strategies, SOCRADES anticipates achieving groundbreaking future applications, in particular process automation and advanced control, based on seamless integration of wired and wireless networks combined with a universal communications infrastructure.

Moreover, main impacts of SOCRADES, hence of intelligent systems adoption, on manufacturing performance have been described and motivated.

Nonetheless there is a need for further research especially in order to validate the impacts described above and to measure the level of impact that they will have on manufacturing performance. This phase is related to the exploitation of the project since it refers to the definition of models and prototypes that show effectively how the developments come out from the projects are really necessary and value-adding in industrial domain.

This is the interest of all the on-going research that try to adopt Service-Oriented Architecture, wireless communication technologies and embedded systems in order to obtain intelligent systems for supporting manufacturing performance. Moreover this will be one of the main next steps of the SOCRADES project, thanks to the project industrial partners involvement.

ACKNOWLEDGMENT

This work has been partly funded by the European Commission through IST project SOCRADES: Service-Oriented Cross-layer infRAstructure for Distributed smart Embedded devices (No: IST-5-034116). The authors wish to acknowledge the Commission for their support. We also wish to acknowledge our gratitude and appreciation to all the SOCRADES project partners for their contribution during the development of various ideas and concepts presented in this paper.

REFERENCES

- [1] SOCRADES website <http://www.socrades.eu>
- [2] F. Jammes, A. Mensch, H. Smit, "Service-Oriented Device Communications using the *Devices Profile for Web Services*" in International Conference on Advanced Information Networking and Applications (ANIA07), 2007.
- [3] S. Karnouskos, O. Baecker, L. M. Sá de Souza, P. Spieß, Integration of SOA-ready Networked Embedded Devices in Enterprise Systems via a Cross-Layered Web Service Infrastructure, 12th IEEE Conference on Emerging Technologies and Factory Automation, Sept. 2007.
- [4] L. M. Sá de Souza, P. Spieß, D. Guinard, M.z Köhler, S. Karnouskos, and D. Savio, SOCRADES: A Web Service Based Shop Floor Integration Infrastructure, Internet of Things 2008 Conference.
- [5] P. Phaithoonbuathong, T. Kirkham, C. S. Mcleod, M. Capers, R. Harrison, R. P. Monfared, Adding Factory Floor Automation to Digital Ecosystems; tools, technology and transformation, IEE DEST 2008.
- [6] D. J. Beebe A.W Colombo, F. Jammes, H. Smit, R. Harrison, J.L.M. Lastra, I.M. Delamer, "Service-oriented architectures for collaborative automation" in Industrial Electronics Society, IECON 2005 31st Annual Conference of IEEE, Nov. 2005.